

# Potentiometers

Ø6mm Phenolic Moulding Type Semi-Fixed Trimming Potentiometers

GP32 Series

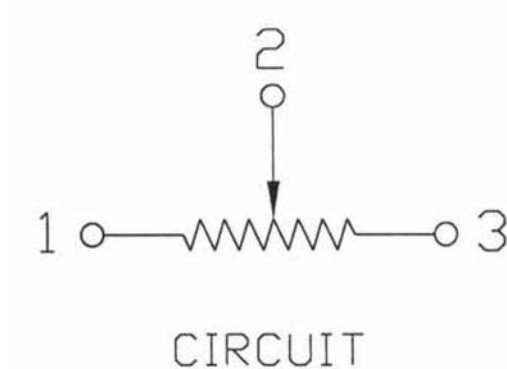
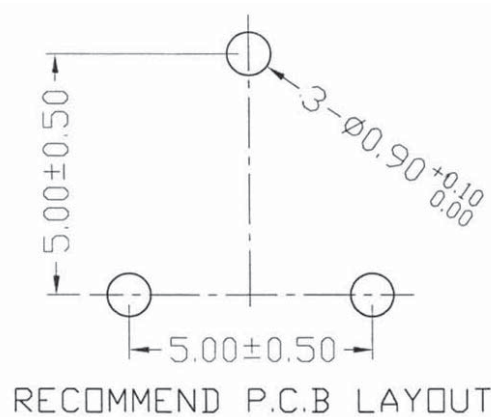
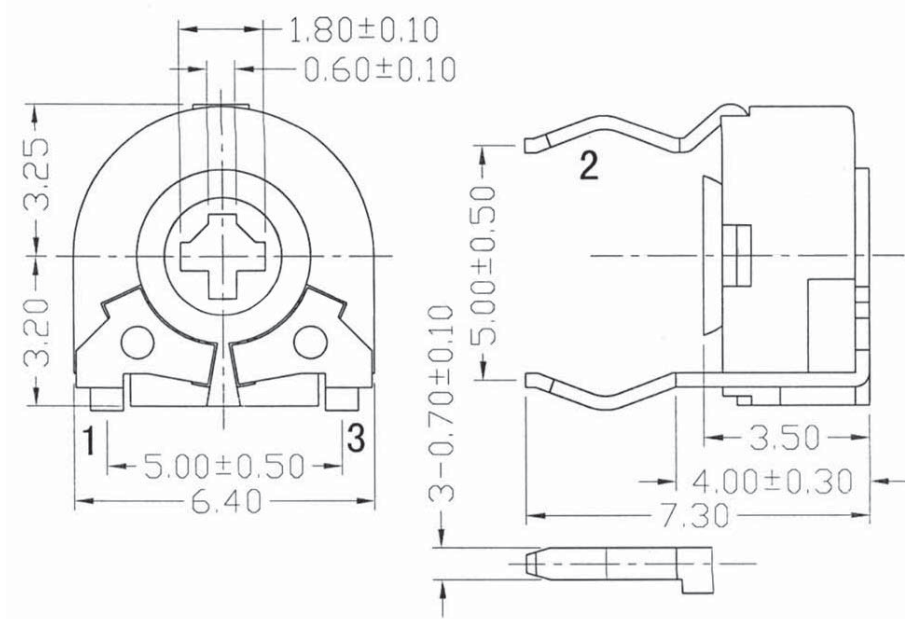

RoHS Compliant

## How to order:

GP32

### 1 TYPE OF TAPER:

- A Logarithm
- B Linear
- C Anti-Logarithm

### 2 RESISTANCE VALUE (Unit: Ω):

free text 500 Ω to 1M Ω  
e.g.: 220K for 220.000 Ω

### 3 RESISTANCE TOLERANCE:

- 20 ± 20%
- 30 ± 30% (Standard)

### 4 ROTATIONAL LIFE:

- N Standard (500 cycles)
- H High Life (10,000 cycles)

## General Specifications:

- > Nominal Resistance: 500Ω to 1MΩ
- > Standard Resistance Tolerance: ± 20%
- > Residual Resistance: less than 10Ω
- > Power Rating: 0.10W for linear taper, 0.05W for other tapers
- > Operating Voltage: 100V for linear taper, 50V for other tapers
- > Rotational Angle: 235°±5°
- > Torque: 20 to 200 g.cm
- > End-Stop Strength: 400 g.cm min.
- > Operating Temperature: -25°C to +40°C
- > Temperature Characteristics: +5% to 30% change in resistance after 5 hours at 70°C
- > Humidity Characteristics: Max. 20% change in resistance after 350 hours at 40°C and RH95% loaded
- > Soldering Method: Hand soldering
- > Soldering Temperature: 260°C
- > Soldering Time: 3 seconds